



Fig.1: NA003-M64

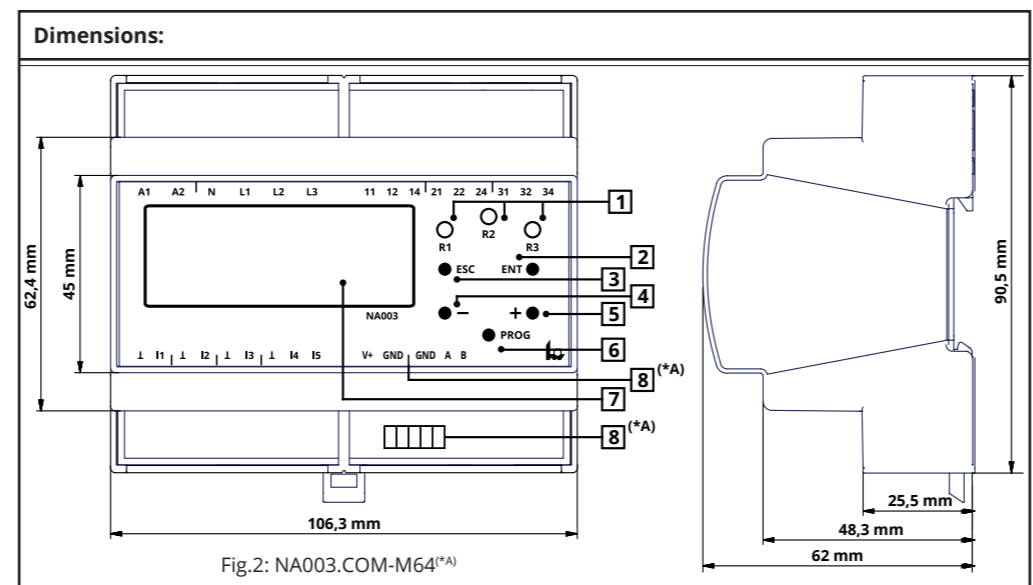

Fig.2: NA003.COM-M64(\*A)

**General document information:**

- The full operation manual is available at: [https://www.tele-online.com/resources/data-sheets/en\\_na003-m64.pdf](https://www.tele-online.com/resources/data-sheets/en_na003-m64.pdf)
- This Quick Start Guide does not replace the manual!
- The safety instructions are to be observed!

(\*A) Is a comment for NA003.COM with serial interface in this document and available with this extended version, only!

**Safety instructions:**

**Danger! Never carry out work on live parts!**  
**Danger of fatal injury!**  
**The product must not be used in case of obvious damage!**  
**To be installed by qualified and authorized personnel only!**

In General: Strictly and always follow safety advices and warnings!  
Do not use this product in case of obvious damage!

The device was developed, produced and tested in accordance to the latest industry standards. Nevertheless improper handling or use can endanger humans and machines. Protection against impairment: The device must be used as prescribed by the manufacturer. Failure to observe these instructions may result in personal injury, property damage, or economic loss. Please use the device only in accordance with the installation and operating instructions. Check for secure assembly and good condition. Moreover, the rules and regulations on accident prevention applicable to the place of use must be strictly followed.

- Eliminate all faults immediately which may endanger safety!
- Do not make any unauthorised changes and only use replacement parts and optional accessories purchased from or recommended by TELE!
- In case of obvious damage the device must be checked and replaced if necessary!
- Country specific regulations have to be considered in any case!
- If required by national standards, the NA003 has to be protected against unauthorized changes by password and/or sealing!

**Intended use:**

The TELE NA003 is a multinational grid and system protection unit, that protects energy generation plants (like combined heat and power plants, wind generators, waterpower plants, photovoltaic plants). In case of power failures or net anomalies, power generating plants have to be disconnected immediately from the mains supply to avoid unintentional feeding to the grid. On the one hand continuing grid feeding could endanger maintenance staffs, on the other hand connected devices could be exposed to inadmissible voltages and/or frequencies.

In case the grid operator requires thresholds and settings that are not conforming with the local standards, it is possible to set thresholds outside the normative defined range! Outside these range the device is not in accordance with the standards anymore and the corresponding certificate loses validity! This state is indicated as „ncnff“ [none conformity] on the display. Settings outside the conformity range are therefore in responsibility of the operator respectively the acceptance authority!

The NA003, especially the NA003.com(\*A) with serial interface can be set with a computer only because further national standards mandated by the local authorities can be read online, only. So, the manual can be downloaded online at [www.tele-online.com](http://www.tele-online.com).

**Controls elements:**

Legend	Marking	Type	Function
1	R1, R2, R3	LED (yellow)	Status indication output relays
2	ENT	Pushbutton	ENTER, input, menu level forward
3	ESC	Pushbutton	ESCAPE, input, menu level back, test/reset
4	-	Pushbutton	Change parameters, menu navigation
5	+	Pushbutton	Change parameters, menu navigation
6	PROG	Pushbutton (sealable)	PROGRAM, enter program mode
7		LCD-Display 4x20 characters	Display
8 (*A)		Modbus Interface (*A)	For serial communication via Modbus RTU

**Terminals:**

A1, A2	Supply	DC: 24V AC: 110 - 230V @ f: 48-63 Hz A1: L (+) A2: N (-)
L1, L2, L3, N	Measuring input	U <sub>N</sub> : 3x400V AC
11, 12, 14	Relay channel A (CO contact) Status indication via yellow LED R1	Isolated changeover contact 11: Common 12: Normally closed contact 14: Normally open contact
21, 22, 24	Relay channel B (CO contact) Status indication via yellow LED R2	Isolated changeover contact 21: Common 22: Normally closed contact 24: Normally open contact
31, 32, 34	Relay channel D (CO contact) Status indication via yellow LED R3	Isolated changeover contact 31: Common 32: Normally closed contact 34: Normally open contact
11, ⊥	Digital input 1 (Feedback contact contactor A)	Contact input (24V/5mA), configurable Input active: I1 connected to ⊥
12, ⊥	Digital input 2 (Feedback contact contactor B)	Contact input (24V/5mA), configurable Input active: I2 connected to ⊥ Does not apply to national standards without functional safety!
13, ⊥	Digital input 3 (Remote disconnection)	Contact input (24V/5mA), configurable Input active: NO->I3 to ⊥ (std); NC->I3 open
14, 15, ⊥	Digital inputs 4 und 5 (Parameter switchover)	Applies to CEI 0-21, C10/11 LV/HV, EN50549-1/2 LV/HV Contact input (24V/5mA) Input active: I4 or I5 connected to ⊥
V+, GND (*A)	Modbus interface RS485 - Supply	+24Vd.c. Supply. <b>Must be connected!</b>
GND, A, B (*A)	Modbus interface RS485 - Communication	Modbus Data interface. <i>Both Modbus GND are internally connected</i>

**Technical data (Part 1):**

<b>Supply circuit</b>	DC: 24V	AC: 110 - 230V	V+/GND: 24V d.c. (*A)
Supply voltage:	DC: ± 10%	AC: ± 30%	V+/GND: ± 15% (*A)
Supply voltage tolerance:	max. 1,35W / 4VA @ 230V AC & Interface 24V d.c. (*A)		
Nominal consumption combined:	max. 1,25W / 4VA @ 230V AC		
Nominal consumption A1/A2:	50 / 60Hz		
Rated frequency:	48 - 63Hz		
Tolerance of rated frequency:	6 kV		
Rated surge voltage:	250V / 500mA slow blow (soldered)		
Internal protection:	<i>In order to ensure the proper function during power failures, an external UPS has to be used for the entire supply (A1/A2 and V+/GND (*A)).</i>		
<b>Measuring circuit</b>	3 x 400V AC		
Measuring input:	1MΩ		
Input impedance:	line to line voltage, line to neutral voltage, 10 minutes average voltage, frequency, rate of change of frequency (RoCoF), phase shift (PShift), Zero Sequence		
Measurand:			
<b>Measuring ranges</b>	0 - 560VAC		
Line to line voltage:	0 - 325VAC		
Line to neutral voltage:	40 - 65Hz		
Frequency:	100mHz/s ... 2.000mHz/s		
RoCoF:	1 - 15°		
Pshift:	Permanent 1,4 x U <sub>Nom</sub> Pulse 1,6 x U <sub>Nom</sub> (1 second)		
Overload capacity:	III		
Overvoltage category:	4 kV		
Rated surge voltage:			
<b>Digital inputs</b>	Isolated, max. wire length <30m, control wiring standards to be taken in account. The ⊥ are not connected to each other. Min. switching voltage/ switching current: 24V DC / 5mA		
Type of contact:			
<b>Output circuit</b>	3 changeover contacts		
Number of contacts:	AgNi		
Contact material:	5A / 250V AC		
Rated current:	100 x 10 <sup>3</sup> switching cycles (AC-1)		
Electrical endurance:	15 x 10 <sup>6</sup> switching cycles		
Mechanical endurance:	5A		
Continuous current value:	5A		
Short time value (1s):	Relay contacts: 1000V <sub>rms</sub> Terminals: 450V <sub>rms</sub>		
Withstanding voltage across open contacts:	III		
Overvoltage category:	4 kV		
Rated surge voltage:	5A fast blow		
Protection:			
<b>Accuracy</b>			
<b>Voltage monitoring:</b>	Base accuracy: < 0,5% @ +25°C		
	Temperature influence: < 0,01% / °C		
	Resolution: 10mV		
<b>Frequency monitoring:</b>	Base accuracy: < 0,01Hz @ +25°C		
	Temperature influence: < 0,0002Hz / °C		
	Resolution: 1mHz		
<b>Ambient conditions and general specifications</b>			
Ambient temperature operation:	-25 ... +65°C		
Ambient temperature storage:	-40 ... +70°C		
Visibility temperature display:	-15 ... +65°C		
Relative humidity:	5 ... 95% (non-condensing)		
Pollution degree:	2		
Weight:	300g		
Installation altitude:	Up to 2000 m above sea level		
Installation:	An external circuit-breaker is required for mains installation to the unit. Installation class 1 must be available in the environment		
Location:	For indoor use only		
Ventilation:	No ventilation of surrounding air required		
Cleaning:	If necessary, the surface of the housing may be cleaned with a dry cloth, only when all sources of power are switch off Power contactors may cause significant disturbances. Therefore, the NA003 should be mounted with a minimum distance of 5 cm to neighbouring power contactors.		
Installation note:			



Connection diagram 1 - in general, activities for FRT\*6 excluded:

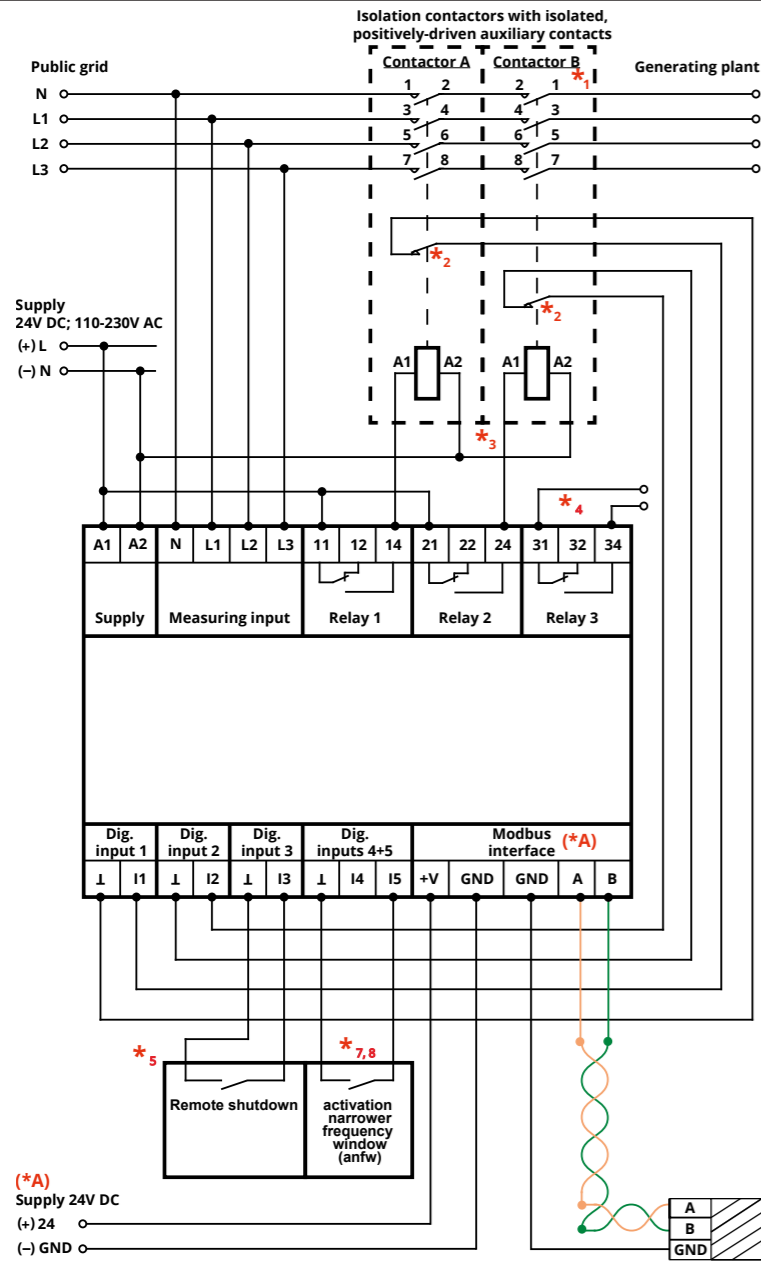

Connection diagram 2 - activities for FRT\*6 included:

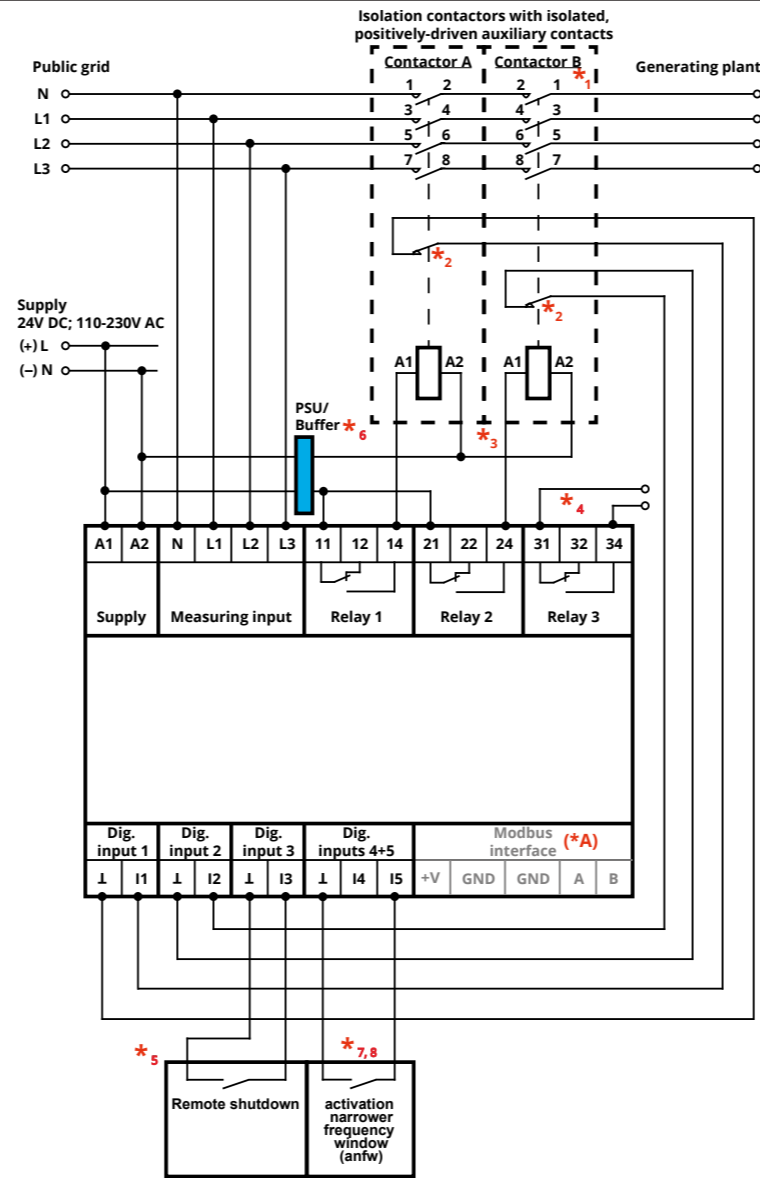

Connection diagram 3 - CEI 0-21 - Italy:

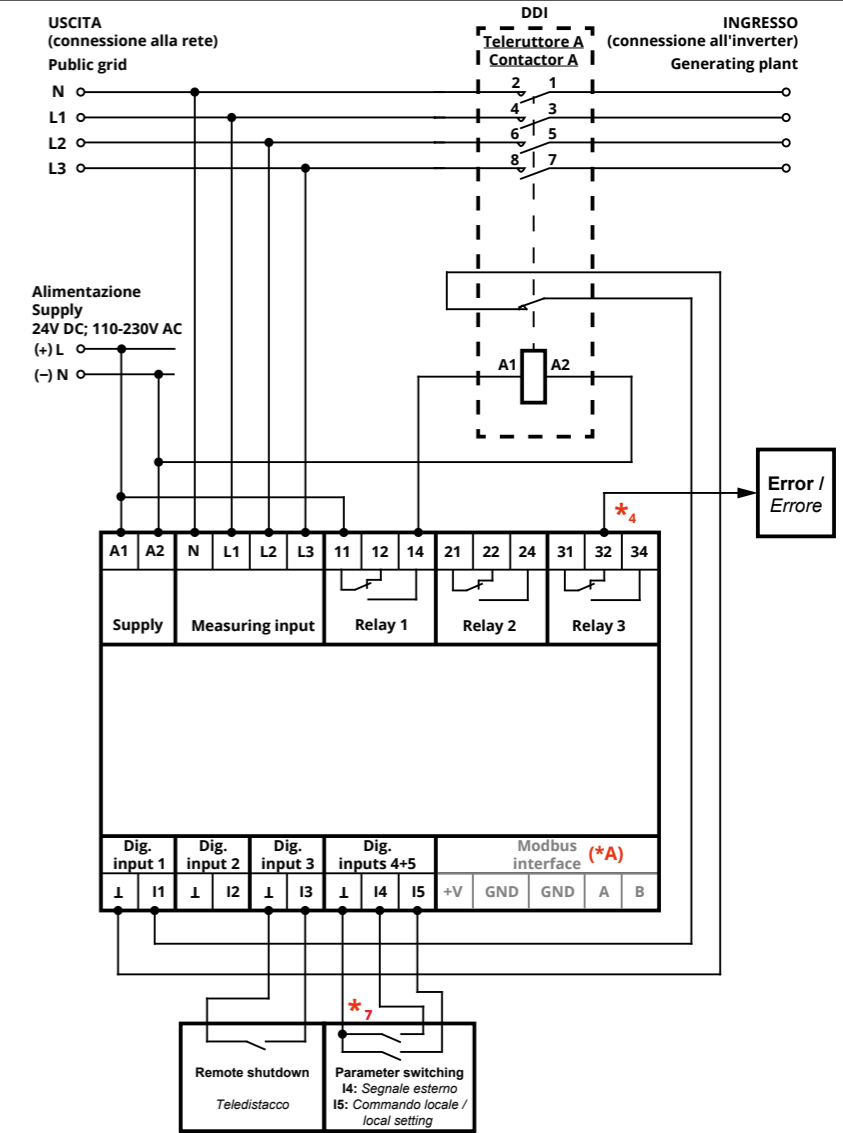

Applies in general to these standards:

- » OVE TOR R25 NS/MS A/SYNC
- » OOE TOR R25 NS/MS A/SYNC
- » W TOR R25 NS/MS A/SYNC
- » TIROL TOR NS/MS A/SYNC
- » VDE-AR-N 4110:2018-11 \*1
- » G99-1-3 LV:2018 \*1
- » G99-1-3 HV:2018 \*1
- » G98-1-2:2018 \*1
- » EN50549-1:2019 LV \*4, \*8
- » EN50549-2:2019 HV \*4, \*8
- » EN50438:2013 DK \*3
- » VDE 0126-1-1:2013
- » AS/NZS 4777.2:2020
- » NRS 097-2-1:2017
- » OPEN SETUP \*3, \*4

Recertified standards:

- » EN50438:2013
- » OVE E 8001-4-712 / E 8101-4-712
- » VDE 0124-100:2013
- » TR3 Rev23:2013 \*1
- » AS/NZS 4777.2:2015
- » G59/3/3:2015 LV \*1
- » G59/3/3:2015 MV \*1
- » G83/2:2012 \*1

Key notes:

- \*1 ... Contactor B not applicable for all country-specific standards in which no functional safety is required!
- \*2 ... Auxiliary contact configurable as "n/o", "n/c" or "disabled"
- \*3 ... 1- or 2-channel connection possible and can be configured.
- \*4 ... Evaluation, contact error for power generation plants mandated for VDE-AR-N 4105:2018-11 and C10-11:2019
- \*5 ... Digital contact as normally opened, normally closed, or "disabled". Default is n.o.
- \*6 ... VDE-AR-N 4105:2018-11 FRT (fault ride through) behavior with buffered isolation contactors.
- \*7 ... Parameter switching see connection diagram 3 - CEI 0-21
- \*8 ... Parameter switching see connection diagram 4 - C10/11
- \*A ... Na003.com serial interface - Modbus RTU with RS485

Applies in specific to:

- » VDE-AR-N 4105:2018-11 (Pn ≤ 50 kW) \*1, \*4, \*6
  - » VDE-AR-N 4105:2018-11 (Pn > 50 kW) \*1, \*4, \*6
  - » VDE-AR-N 4105:2018-11 (Inverter) \*4, \*6
- \*6 FRT - fault ride through:** behavior with buffered isolation contactors, Power supply / buffer. Isolation contactors and coupling relays, if present, must be buffered for 3s/0.3s in the event of undervoltage (FRT).
- Power generation devices into low-voltage networks must help to stabilize the network. Therefore, the isolating contactor must not drop out at a voltage just above  $U << (0.45 U_n)$  or 0.3s in the event of a voltage interruption due to undervoltage. Only the NA003 switches the contactor off after 3s ( $U <$ ) or 0.3s ( $U <<$ ). A power supply / buffer is required.
- When using 2 isolating contactors, both must be supplied for 3s. The NA003 has an internal broadband power supply and therefore does not need a buffered control voltage.

Applies in specific to:

- » CEI 0-21:2019 \*1, \*4, \*7
- \*7 ... Parameter switching (CEI):
  - **definitive mode (Operational mode 0):**
    - 14 inactive / contact open: overfrequency 1, underfrequency 1
    - 14 active / contact closed: overfrequency 2, underfrequency 2
  - **transitory mode (Operational mode 1):**
    - 15 active / contact closed: overfrequency 2, underfrequency 2
    - 15 inactive / contact open: overfrequency 3, underfrequency 3

Sonnection diagram 4 - C10-11 - Belgium:

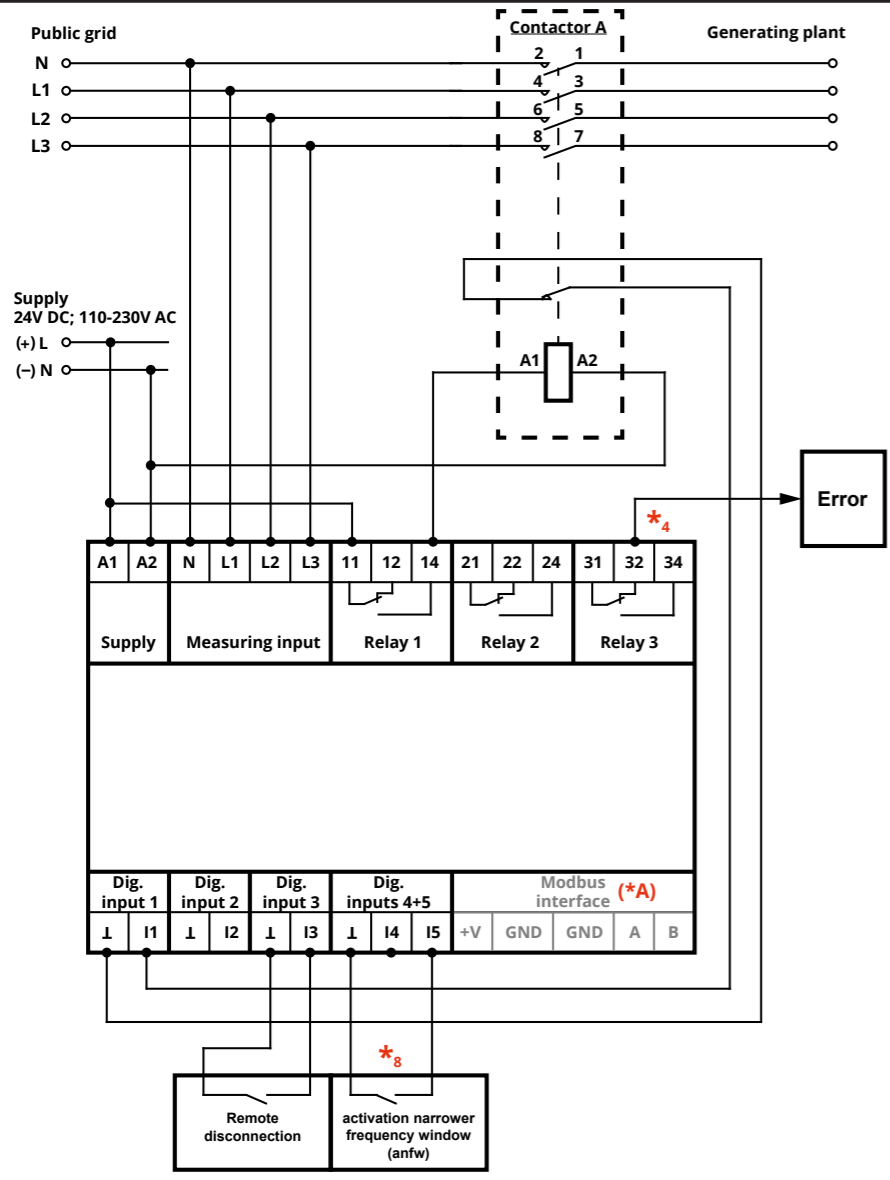

Applies in specific to:

- C10-11:2019 LV-ASS \*1, \*4, \*8
- C10-11:2019 HV-ASS \*1, \*4, \*8
- C10-11:2021 LV-IP \*1, \*4, \*8
- C10-11:2021 HV-IP \*1, \*4, \*8

- Recertified standards:
- C10-11:2012 LV \*1, \*4
  - C10-11:2012 MV \*1, \*4
  - C10-11:2019 LV \*1, \*4, \*8
  - C10-11:2019 HV \*1, \*4, \*8

\*8 ... Parameter switching (C10/11):  
 I5 inactive / contact opened: Overfrequency 1, Underfrequency 1  
 I5 active / contact closed: Overfrequency 2, Underfrequency 2 (narrower frequency window) (based on local voltage criteria / local setting)

Implemented standards:

Slot	ID	Norm/Standard	Regions	Number of channels		
				1	2 Funct. safety	1 or 2 select able
#00	802	OVE TOR R25 NS SYNC	Austria (low voltage)		X	
#01	803	OVE TOR R25 NS ASYNC	Austria (low voltage)		X	
#02	852	OVE TOR R25 MS SYNC	Austria (medium voltage)		X	
#03	853	OVE TOR R25 MS ASYNC	Austria (medium voltage)		X	
#04	822	OOE TOR R25 NS SYNC	Upper Austria Oberösterreich (low voltage)		X	
#05	823	OOE TOR R25 NS ASYNC	Upper Austria Oberösterreich (low voltage)		X	
#06	872	OOE TOR R25 MS SYNC	Upper Austria Oberösterreich (medium voltage)		X	
#07	873	OOE TOR R25 MS ASYNC	Upper Austria Oberösterreich (medium voltage)		X	
#08	832	W TOR R25 NS SYNC	Vienna (low voltage)		X	
#09	833	W TOR R25 NS ASYNC	Vienna (low voltage)		X	
#10	882	W TOR R25 MS SYNC	Vienna (medium voltage)		X	
#11	883	W TOR R25 MS ASYNC	Vienna (medium voltage)		X	
#12	812	TIROL TOR NS SYNC	Tyrol (low voltage)		X	
#13	813	TIROL TOR NS ASYNC	Tyrol (low voltage)		X	
#14	862	TIROL TOR MS SYNC	Tyrol (medium voltage)		X	
#15	863	TIROL TOR MS ASYNC	Tyrol (medium voltage)		X	
#16	311	VDE-AR-N 4105: 2018 (Pn ≤ 50kW)	Germany (low voltage)	X		
#17	312	VDE-AR-N 4105: 2018 (Pn > 50kW)	Germany (low voltage)	X		
#18	313	VDE-AR-N 4105: 2018 (converter)	Germany (low voltage)		X	
#19	706	VDE-AR-N 4110: 2018 (Pn > 135kW)	Germany (medium voltage)	X		
#20	102	CEI 0-21: 2019	Italy	X		
#21	410	G99/1/3: 2018 LV	Great Britain (low voltage)	X		
#22	460	G99/1/3: 2018 HV	Great Britain (medium/high voltage)	X		
#23	510	G98/1/2: 2018	Great Britain (low voltage)	X		
#24	603	C10-11: 2021 LV-IP	Belgium (low voltage) interface protection	X		
#25	602	C10-11: 2019 LV-ASS	Belgium (low voltage) automatic separation system	X		
#26	653	C10-11: 2021 HV-IP	Belgium (medium/high voltage) interface protection	X		

Slot	ID	Norm/Standard	Regions	Number of channels		
				1	2 Funct. safety	1 or 2 select able
#27	652	C10-11: 2019 HV-ASS	Belgium (medium/high voltage), automatic separation system	X		
#28	1200	NA/EEA- CH 2014 (Type A)	Switzerland 2014 (low voltage)		X	
#29	1220	NA/EEA-NE7 - CH 2020 (Type A)	Switzerland 2020 (low voltage)		X	
#30	1221	NA/EEA-NE7 - CH 2020 (Type B)	Switzerland 2020 (low voltage)		X	
#31	901	EN 50549-1:2019	Europe LV (Netherlands)		X	
#32	926	EN 50549-2:2019	Europe HV (Netherlands)		X	
#33	950	EN 50438: 2013 DK	Denmark			X
#34	200	VDE V 0126-1-1:2013	France, Turkey, Belgium, Greece, ...		X	
#35	1110	AB AS 4777.2:2020	Australia		X	
#36	1120	C AS 4777.2:2020	Australia		X	
#37	1130	NZS 4777.2:2020	New Zealand		X	
#38	1000	NRS 097-2-1: 2017	South Africa		X	
#39	9006	OPEN SETUP	Freely configurable setup			X

Recertified Standards						
Slot	ID	Norm/Standard	Regions	1	2 Funct. safety	1 or 2 select able
#52	900	EN 50438:2013	Europe		X	
#53	801	OVE E 8001/8101:2014	Austria		X	
#54	300	VDE-AR-N 4105 tested according to VDE 0124-100:2013	Germany (low voltage)		X	
#55	700	TR3 Rev23:2013 certified according to BDEW 2008	Germany (medium voltage)	X		
#56	1102	AS/NZS 4777.2:2015	Australia / Victoria (New Zealand)		X	
#57	405	G59/3/3: 2015 LV	Great Britain (low voltage)	X		
#58	455	G59/3/3: 2015 MV	Great Britain (high voltage)	X		
#59	500	G83/2: 2012	Great Britain (low voltage)	X		
#60	600	C10-11: 2012 LV	Belgium (low voltage)	X		
#61	650	C10-11: 2012 MV	Belgium medium voltage	X		
#62	601	C10-11: 2019 LV	Belgium (low voltage)	X		
#63	651	C10-11: 2019 HV	Belgium (high voltage)	X		